

# Self-Contained Auger Compactor



Easy to use and maintenance friendly

Always moves material forward

Ideal for wet waste such as medical or organic

Whisper quiet

# Self-Contained Auger Compactor

Marathon's Self-Contained Auger Compactors are easy to use and maintenance friendly. Features such as the short tail for dock feeding, or rear feeding, and the check valve action that assures materials stay in the container, all add up to a reliable auger compactor for years of trouble-free performance.

The advantages of using an Auger Compactor

- » Denser waste volume, reducing transport movements and cost
- » Minimize waste storage space on site

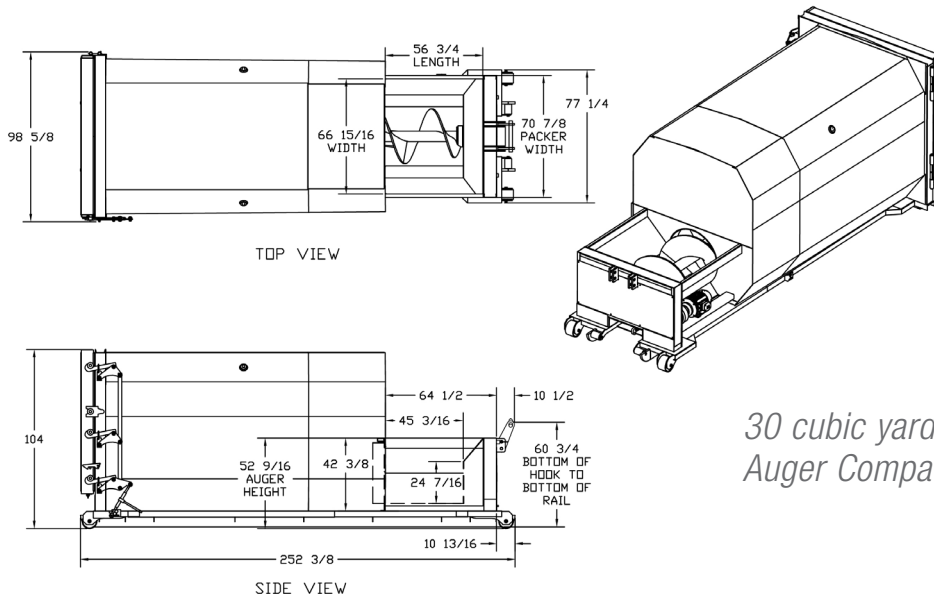

*30 cubic yard Self-Contained Auger Compactor*

Specifications for AST-220		
Head Weight	4,100 lbs	1,850 kg
Auger Diameter	36"	900 mm
Container Penetration	13"	330 mm
Charge Chamber Size	1.1 yd <sup>3</sup>	.84 m <sup>3</sup>
Performance Characteristics		
Auger Speed	9 rpm	9 rpm
Cycle Time	13 sec	13 sec
Displacement Rate	305 yd <sup>3</sup> /hr	235 m <sup>3</sup> /hr
Electrical Equipment		
Electric Motor 3/60/230-460	15 hp	11 kW

Visit [www.marathonequipment.com](http://www.marathonequipment.com) to learn more about how Marathon Solutions are making a difference around the world.



**Marathon Equipment Company**  
 P.O. Box 1798  
 Vernon, AL 35592-1798  
 800.633.8974



Pictures in this literature are illustrative only. Specifications are subject to change without notice in order to accommodate improvements to the equipment. Complies with ANSI standard Z245.2, and applicable OSHA Regulations. Products must be used with safe practice and in accordance with said operator manual and applicable regulations and standards.