



Home Of



SUPERIOR COMPACTION SYSTEMS

Model M300L

FEATURES

- Heavy duty construction
- Automatic multi-cycle operation
- Low maintenance

OPTIONS

- CAT3 safety panel
- Pin off systems
- Odor control equipment
- Oil heater
- Remote jog controls
- Enclosures

IDEAL FOR



Supermarkets



Department Stores



Commercial



Industrial



Hospitals



Hotels



Malls

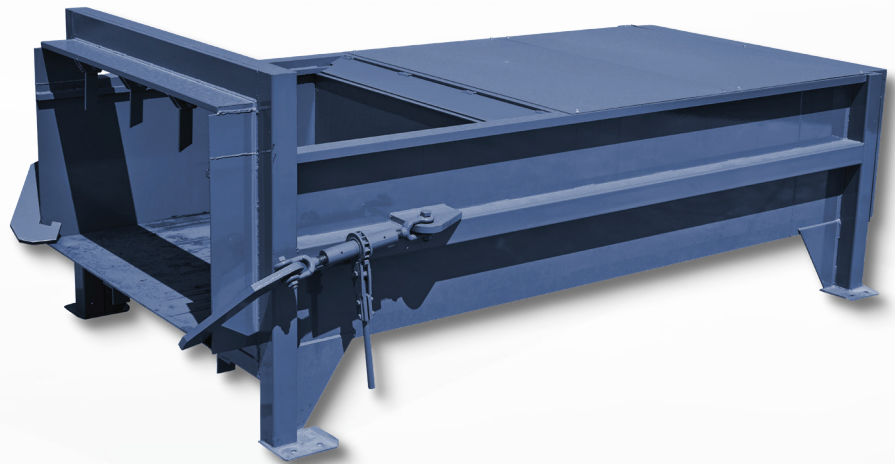

Powered By





Home Of



SUPERIOR COMPACTION SYSTEMS

Model M300L

SPECIFICATIONS

Items	Model M300L
Length A	160"
Width B	79"
Height C	45"
Charging area	3 cu. yd.
Clear top opening D	60" x 60"
Frame	
Floor	1/2"
Side	3/8"
Ram	
Face - Wx H	60" x 27"
Floor	1/2"
Top	3/8"
Sides	3/8"
Guides	1" x 1" FB
Penetration	21"
Breaker Bars	6" x 5" x 1" FB
Cylinder	
Bore	6"
Stroke	78"
Motor Rating	15 HP
Cycle Time	68 sec
Electrical Requirements	208/575
Ram Force	56,000 lb.
System Pressure	2000 psi

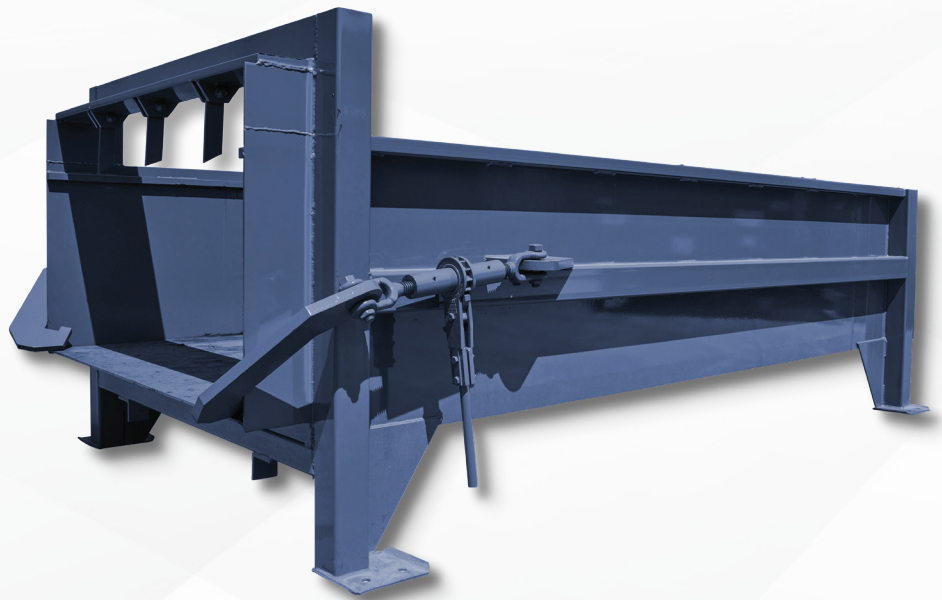
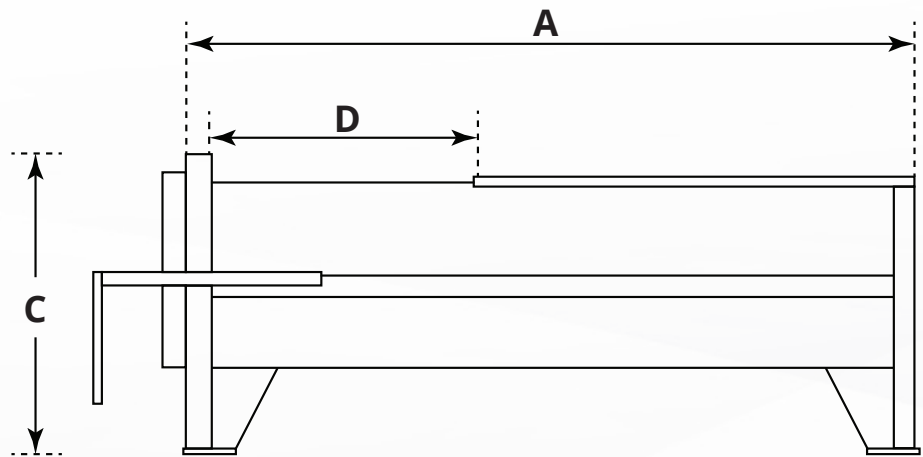

✉ sales@metrocompactor.com ☎ 416-743-8484 📍 145 Heart Lake Rd S, Brampton, ON L6W 3K3

www.metrocompactor.com



Refurbished
Options Also Available